

LA CUCINA NASCOSTA / THE HIDDEN KITCHEN



**LA CUCINA NASCOSTA
/ THE HIDDEN KITCHEN**

La cucina nascosta

La cucina nascosta si integra negli spazi fino a fondersi con le architetture, combinando modularità e libertà progettuale grazie alle infinite configurazioni di finiture e dettagli. Che sia il minimalismo estetico di *Sesamo*, con l'elegante apertura ad un solo movimento, o la versatilità del sistema *Ante rientranti*, in grado di assolvere molteplici funzioni, la cucina nascosta dà vita a possibilità progettuali sempre diverse, in armonia con l'ambiente circostante.

The hidden kitchen becomes part of the space, merging with the architecture, and combining a modular build with a freedom to create in an infinite array of finishes and details. SESAMO offers aesthetic minimalism, with its elegant single-movement opening, while the POCKET-DOOR mechanism provides versatility, performing many functions: the hidden kitchen allows you to keep changing your interior design to suit the surroundings.

















L'anta rientrate ha un movimento di inserimento ed estrazione assistita che permette un fluido scorrimento e al tempo stesso nasconde i moduli funzionali. Nella foto il modulo forno più micro. / The pocket doors have an assisted insertion and extraction motion, meaning they slide smoothly, while concealing practical units behind. Oven and microwave unit shown in the image.



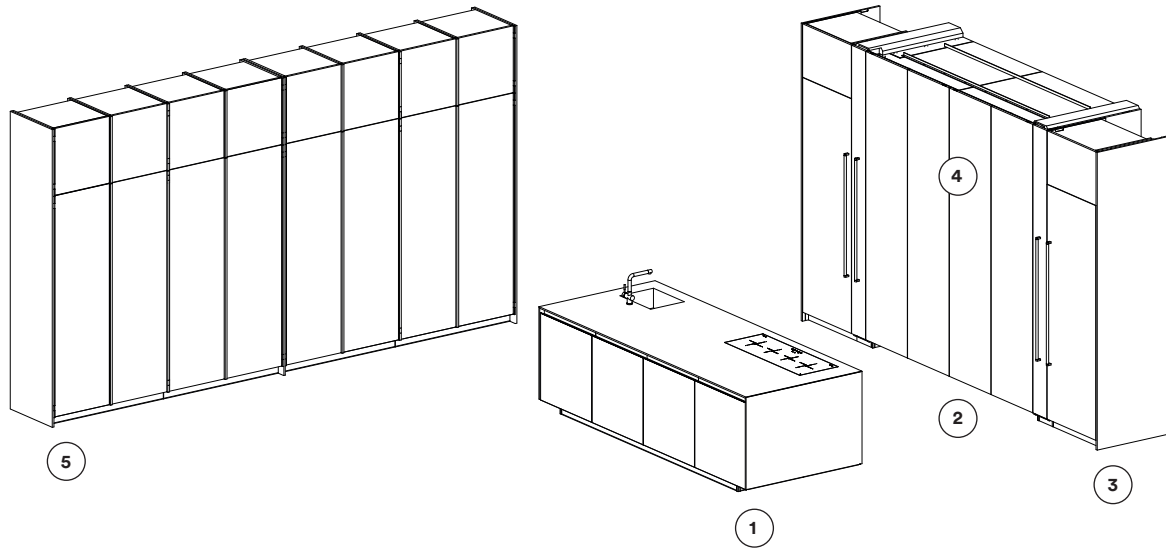

1 BASI ISOLA / ISLAND BASE UNITS

Basi Zafferano e top Pietra Luxury Camouflage, gola e zoccolo Moka shine./ Zafferano Island base units and top Camouflage Luxury stone, groove and plinth Moka shine.

2 COLONNE SESAMO / SESAMO TALL UNITS

Colonne Sesamo laccato micalizzato Nickel, maniglia C60 Nickel satinato, interno Fashion wood rovere Naturale, Top e schienale Pietra Luxury Camouflage, gola Sesamo tall units Micalised Nickel lacquer, C60 brushed Nickel handle, Fashion wood rovere Naturale oak interior, Top and back in Camouflage Luxury stone, Fashion wood rovere Naturale oak groove and Nickel plinth, Metal shelves Moka shine.

3 COLONNE / TALL UNITS

Colonne con ante rientranti laccato micalizzato Nickel, maniglia C60 Nickel satinato, interno antracite e zoccolo Nickel./ Tall units with pocket doors Micalised Nickel lacquer, C60 brushed Nickel handle, antracite interior and Nickel plinth.

4 MODULI FLAG / FLAG UNITS

Moduli Flag moka stone. / Flag units Moka stone.

5 COLONNE CANVAS / CANVAS TALL UNITS

Colonne Canvas anta vetro trasparente grigio, telaio Moka shine, scocca e schiena Fashion wood rovere Naturale./ Canvas tall units Grigio transparent glass door, Moka shine frame, body and back panel Fashion wood Naturale oak.

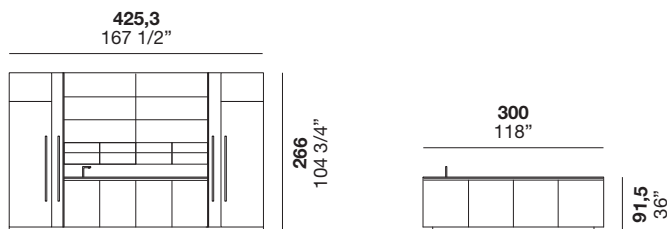

Colonne Sesamo / Tall units Sesamo

Isola / Island

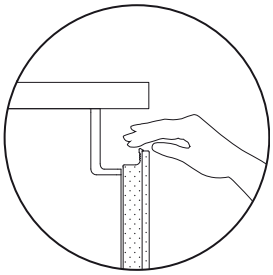

Apertura con gola curva, telaio Zafferano / Opening with curved groove, Zafferano frame



Basi / Base units

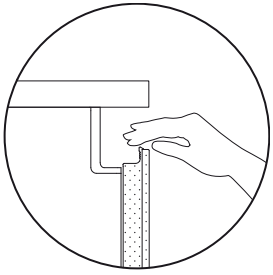

Apertura con gola curva, telaio Zafferano / Opening with curved groove, Zafferano frame



Isola / Island

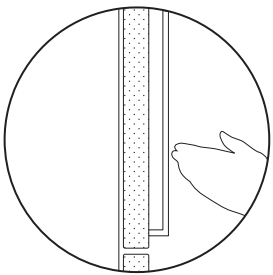

Apertura con maniglia / Opening with handle



Colonne / Tall units

Sesamo

Come una quinta teatrale, con un solo movimento fluido e morbido, Sesamo si apre alla progettualità e al tempo stesso nasconde al suo interno tutte le funzionalità di una cucina completa. La fascia di copertura è un sipario che rende elegante la cucina sia quando è aperta, sia quando è chiusa. Sullo sfondo un palco in cui la libertà di configurazione degli elementi la fa da protagonista, con l'illuminazione a led ad arricchirne l'atmosfera. Un solo movimento che scopre all'interno molto più di una cucina: un nuovo concetto di abitare e vivere lo spazio.

Like the curtains of a theatre stage, Sesamo opens up with one smooth, fluid movement, to new designs. Behind, it hides all the practical features of a fully functional kitchen. The cover panel dresses the kitchen, giving it an elegant look both when open and closed. The freely configurable unit behind takes centre stage, with LED lighting to create atmosphere. One simple movement to part the stage curtains reveals much more than a kitchen: it unveils a new concept of living and a new way of experiencing the space.











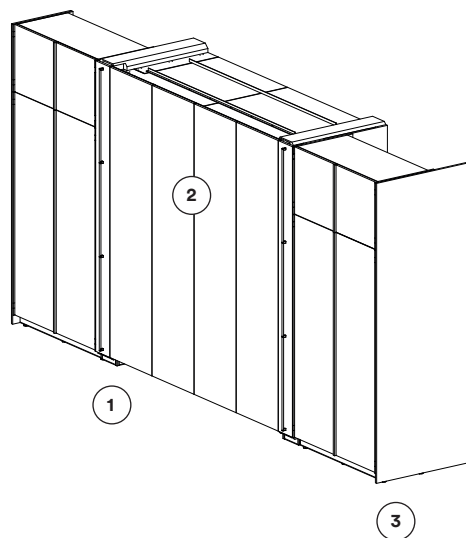

1 COLONNE SESAMO / SESAMO TALL UNITS

Colonne Sesamo Fashion wood Rovere Carbone, Maniglia C70 Antracite, Basi e pensili laccato opaco Fango, Top e schienale Laminam Fokos Roccia, zoccolo Moka shine. / Sesamo tall units Fashion wood Carbone oak, C70 Antracite handle, Top and back in Laminam Fokos Roccia, Moka shine plinth.

2 MODULI FLAG / FLAG UNITS

Moduli Flag moka stone. / Flag units Moka stone.

3 COLONNE CANVAS / CANVAS TALL UNITS

Colonne Canvas anta vetro trasparente grigio, telaio Moka shine, scocca e schiena Fashion wood rovere Carbone. / Canvas tall units Grigio transparent glass door, Moka shine frame, body and back panel Fashion wood Carbone oak.

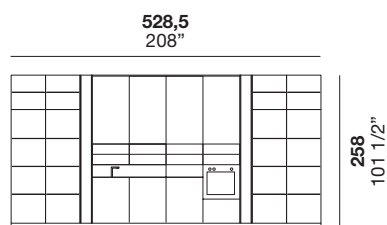

Colonne Sesamo e Ante rientranti / Sesamo tall units with pocket doors

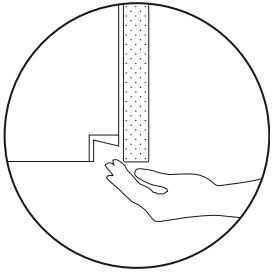

Apertura con gola / Opening with groove

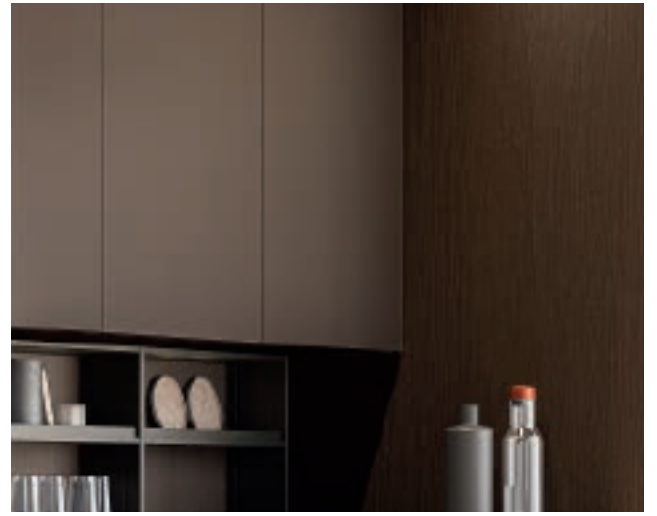

Pensili / Wall units

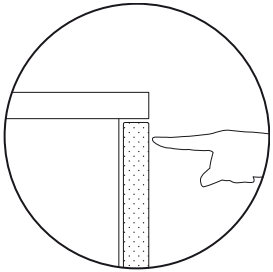

Apertura push pull / Opening with push pull



Basi / Base units

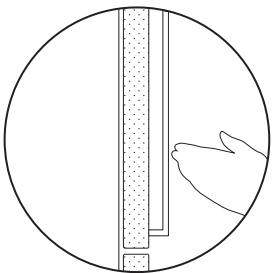

Apertura con maniglia / Opening with handle

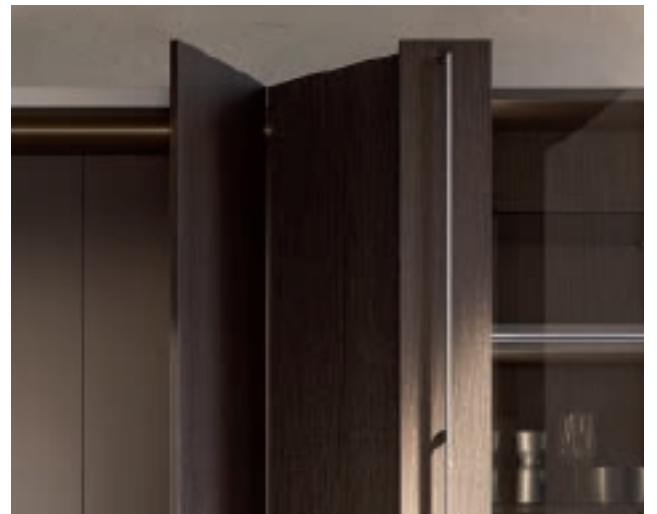

Colonne / Tall units

Ante rientranti

L'anta rientrante fonde pulizia estetica e modularità. Una colonna a una o due ante attrezzabile liberamente in base alle necessità progettuali. L'anta a scomparsa con movimenti di rientro ammortizzato nasconde al suo interno molteplici configurazioni, dalla cucina alla lavanderia. Moduli affiancabili tra loro per creare un sistema che interpreti al meglio lo spazio e le esigenze di chi lo abita.

Pocket doors combine sleek aesthetics with a modular design. A tall unit with one or two doors can be equipped to suit your design requirements. The concealed pocket doors with soft close can be used to conceal multiple configurations, from kitchen units to laundry units. These units can be used side by side, to create the perfect composition for your space and needs.













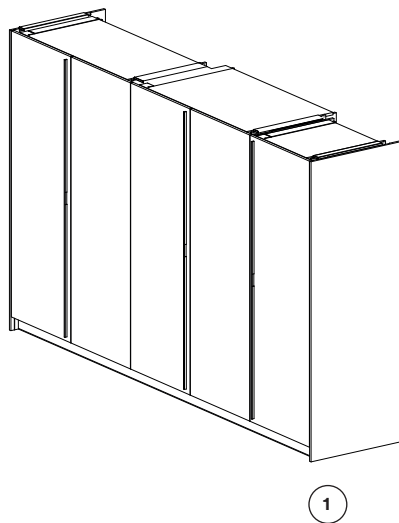

1 COLONNE / TALL UNIS

Colonne con ante rientranti Noce Naturale, maniglia MZ e zoccolo Moka shine, Top e schienale Acciaio satinato, gola Moka shine, Cassetti Antracite. / Tall units with pocket doors in Naturale walnut, MZ handle and plinth Moka shine, Top and back in satin steel, groove Moka shine, Antracite drawers.

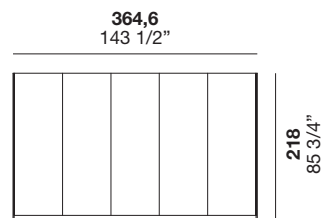

Colonne Ante rientranti / Tall units with pocket doors

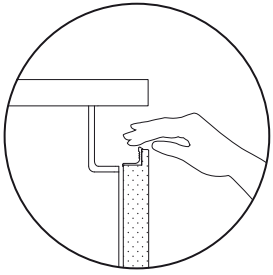

Apertura con gola curva, profilo L90 / Opening with curved groove, L90 profile



Basi / Base units

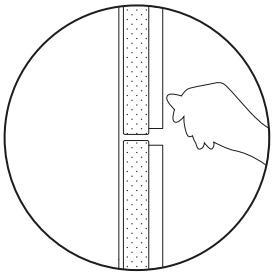

Apertura con maniglia / Opening with handle



Colonne / Tall units











comp. 04

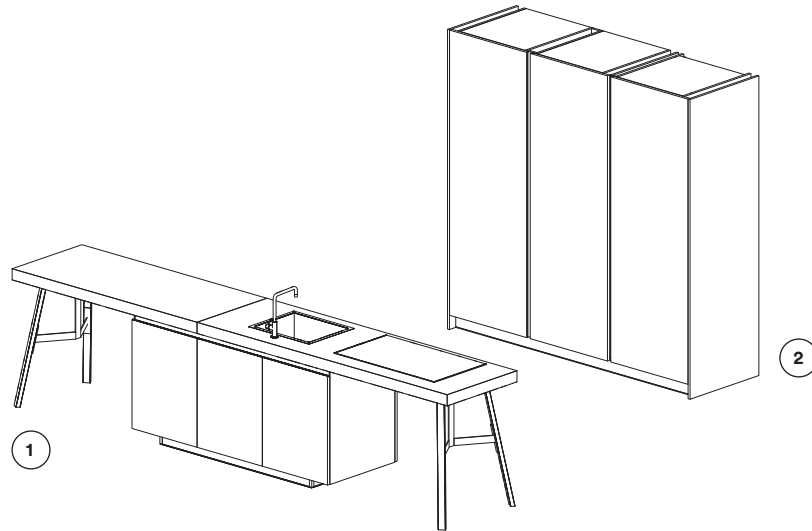

1 BASI / BASE UNITS

Basi laccato opaco Bianco, gola e profilo "L40" laccato opaco Bianco, zoccolo laccato opaco Bianco, top Fenix Bianco Kos, gamba penisola "Titan" Moka Shine.

/ Matt lacquered Bianco base units, matt lacquered Bianco base units, matt lacquered Bianco groove and "L40" profile matt lacquered Bianco plinth, Fenix Bianco Kos top, Moka Shine "Titan" peninsula leg.

2 COLONNE / TALL UNITS

Colonne con ante rientranti Laccato opaco Platino, gola laccato opaco Platino, profilo "L40" Moka Shine. / Matt lacquered Platino tall units with pocket doors, matt lacquered Platino groove, Moka Shine "L40" profile.

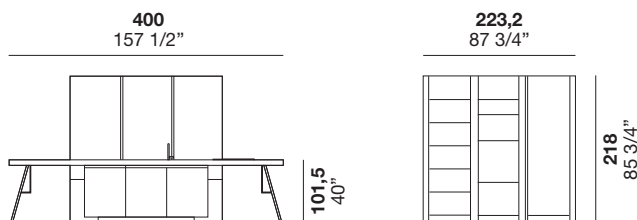

Bar snack / Breakfast bar base unit

Colonne ante rientranti / Tall units with pocket doors

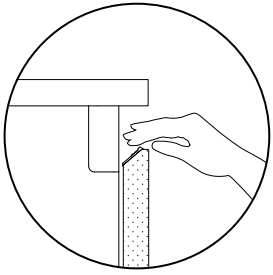

Apertura con gola piatta, profilo L40 / Opening with flat groove and L40 profile



Basi / Base units

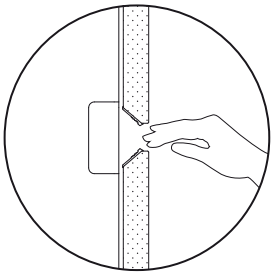

Apertura con gola piatta, profilo L40 / Opening with flat groove and L40 profile



Colonne / Tall units







BASI / BASE UNITS

Basi nobilitato Noce, gola Moka Shine, profilo "L90" e zoccolo Moka shine, top Laminam Fokos Sale. / Surfaced Walnut base units, Moka shine groove, "L90" profile and plinth, Laminam Fokos Sale top.

PENSILI / WALL UNITS

Pensili nobilitato Metal bronze. / Surfaced Metal bronze wall units.

COLONNE / TALL UNITS

Colonne con ante rientranti nobilitato Metal bronze, interno Antracite Maniglia P42 e zoccolo Moka shine. / Surfaced Metal bronze wall units with pocket doors Antracite body Moka shine P42 handle and plinth.

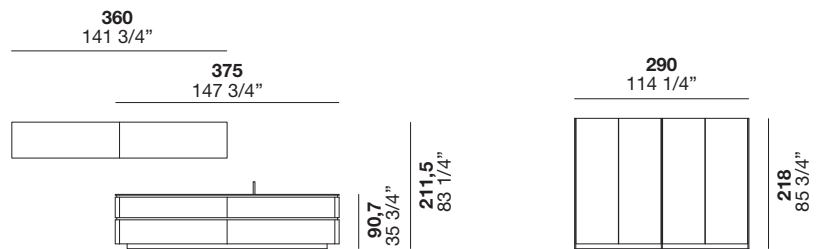

Pensili, basi / Wall units, base units

Colonne / Tall units



718,1
282 3/4"

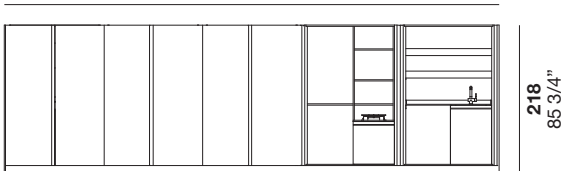

218
85 3/4"

COLONNE / TALL UNITS

Colonne con ante rientranti laccato opaco Platino, interno Antracite Piano Corian Glacier white, maniglia MZ e zoccolo Moka Shine. / Matt lacquered Platino wall units with pocket doors, Antracite body Corian Glacier white top, Moka shine MZ handle and plinth.

Colonne / Tall units



Abaco della qualità

Ergonomia

L'ergonomia è un concetto guida per Valdesign e si realizza attraverso moduli appositamente studiati e la combinazione degli stessi. Moduli per una progettazione sartoriale dove l'individuo e le sue esigenze sono poste al centro.

ERGONOMICS

Ergonomics is key at Valdesign: units are always carefully planned out and combined together with this concept in mind. Together they create a tailor-made design, where individual needs are front and centre.



Funzionalità e affidabilità

L'attenzione e cura nei dettagli sono linee guida in ogni parte delle cucine Valdesign. Tutti i cassetti sono forniti di guide in acciaio con una portata collaudata di 40 kg alla coppia per profondità fino a 50 cm e 70 kg alla coppia per profondità 60 cm e movimenti garantiti per 80.000 cicli di apertura e chiusura. Ogni mobile è dotato di ferramenta dei più elevati standard quali cerniere ad innesto rapido con ammortizzatore di chiusura per le ante e guide con chiusura assistita per cassetti e cestoni. Tutto volto a garantire l'affidabilità nel tempo.



FUNCTIONALITY AND AESTHETICS
Care and attention to detail permeate every aspect of Valdesign kitchens. All drawers are supplied with steel runners which are tested to support a load of 40 kg per pair for depths up to 50 cm, and 70 kg per pair for depths of 60 cm. Movement guaranteed for 80,000 opening and closing cycles. Each unit comes with high-quality fixtures and fittings. These include snap-in hinges with assisted closing for the doors and soft-close runners for the drawers. The overarching aim is to ensure our products are reliable over time.

Manutenzione

La durabilità di una cucina si ha attraverso la cura e manutenzione dei suoi elementi. Per questo Valdesign fornisce un set di prodotti per la manutenzione e pulizia volto a preservare ed esaltare le qualità e peculiarità estetiche dei materiali.

MAINTENANCE

Kitchens need to be cared for and maintained to ensure they last. Valdesign provides a maintenance and cleaning kit to protect and enhance the unique look and characteristics of the materials.



Laccatura e verniciature

Il nostro processo di laccatura prevede la spazzolatura nel caso della finitura lucida in tutte le superfici a vista. Le finiture Fashion wood e Rovere laccato sono realizzate con ciclo di verniciatura all'acqua.

LACQUERING AND PAINTING

Our lacquering process includes brushing to achieve the high-gloss finish for all visible surfaces. The Fashion Wood and lacquered oak finishes are created using water-based paint.

Scocche

Tutti i pannelli che utilizziamo per le nostre cucine sono EPA CARB. Tutte le nostre scocche sono idrorepellenti (IDROLEB).

CARCASSES

All the panels we use for our kitchens are EPA CARB certified. All unit bodies are water-repellent (IDROLEB).

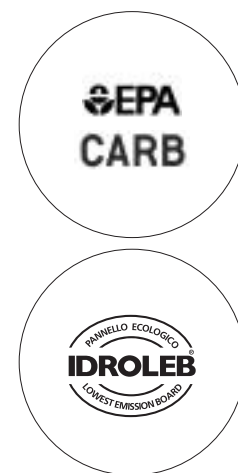

Valdesign®

cucine

VALDESIGN srl
Via A. Luciani 70
31043 Vallonto di Fontanelle
Treviso, Italy
Tel. +39 0434 769811
Fax +39 0434 769845
www.valdesigncucine.it
info@valdesigncucine.it

Verifica le finiture disponibili sul nostro sito internet / Check the finishes available on our website www.valdesigncucine.it

ALF UNO s.p.a. si riserva di apportare in qualsiasi momento modifiche a prodotti, misure e materiali, che ritenesse utili per esigenze di carattere produttivo e commerciale. Per essere sempre aggiornati vi invitiamo a consultare il nostro sito internet www.valdesigncucine.it. LE FINITURE: I materiali utilizzati dalla nostra azienda sono selezionati tra i più affidabili per applicazione e resa estetica. Nonostante questo devono considerarsi tollerabili alcune differenze dovute alle caratteristiche stesse di materiali come essenze naturali, vetri, laccature e all'artigianalità di alcune fasi del processo produttivo che da sempre è un nostro valore aggiunto. Inoltre alcune finiture possono subire nel tempo maturazioni dovute all'azione della luce e del tempo. È importante quindi specificare se nell'ordine vi sono sostituzioni o completamenti per valutare insieme il miglior modo di procedere. Le tonalità di colore e le finiture illustrate vanno considerate puramente indicative. Verificare sempre la fattibilità dell'abbinamento finiture consultando l'interno del listino.

ALF UNO s.p.a. reserves the right to make any changes to products, measurements and materials at any time deemed useful for manufacturing and sales purposes. To stay up to date at all times, please visit our website www.valdesigncucine.it. FINISHES: The materials we use are selected among the most reliable products in terms of application and aesthetic rendering. Despite this, certain differences due to the very characteristics of materials such as natural wood finishes, glass and lacquers must be considered tolerable, as well as the hand-crafted nature of certain phases of the production process, which has always been one of our added values. In addition, some finishes may change over time, due to the effects of light and time. It is therefore important to specify whether there are replacements or completions in the order to assess the best way to proceed together. The finishes featured in this sample collection are purely indicative and are not available for all products. Please check in the price list if the finish is available for the chosen item. Orders will not be accepted for products with finishes not included in the price list. The colour shades and finishes illustrated herein are to be considered purely indicative. Always check the feasibility of finish combinations by consulting the price list contents.

art direction **Bruna Vaccher, Genny Canton** / graphic design **Genny Canton Studio** / digital image **Nudesign** / photo **Riccardo Munarin** / styling **Rosanna Bignucolo, Claudia Barberi** / separations **Luce srl** / print **Sincromia**



